

Riviera Series

(Styles C30, C301, C30R, C301R, C31, C311, C32, C321, C33, C331, C34, C341)

Installation Instructions



- These instructions must be followed exactly as written and the materials used must be exactly as shown in the instructions. Any deviation from the instructions or variation in the materials used/installed may result in an unsuccessful installation.
- When core drilling any post product where water can build up, the installer is responsible to drill a 1/4" hole as close to the bottom of the post by concrete as possible. If there is no weep hole, you may have damage from moisture build up and freezing thus potentially voiding the powder coating warranty.

Installing Aluminum Post w/Adjustable Plate

1. Place the (2) stainless steel strips below the plate under the leveling bolts.
2. **For concrete installation**, fasten aluminum post to concrete using (4) 3/8" x 3" or longer concrete anchors (anchors not included).

For wood surface installation, fasten aluminum post to wood surface using (4) 5/16" x 4" or longer stainless steel lags (lags not included). **WARNING: When installing the Aluminum Post on top of a wood structure, the 4" lags MUST be lagged into at least 3" of solid wood! It will not be strong enough if it is fastened into a 5/4" or a 1 1/2" thick deck board! Below is an example of how to design the wood structure to accept the Aluminum Post. Any other way must meet or exceed these qualifications.**

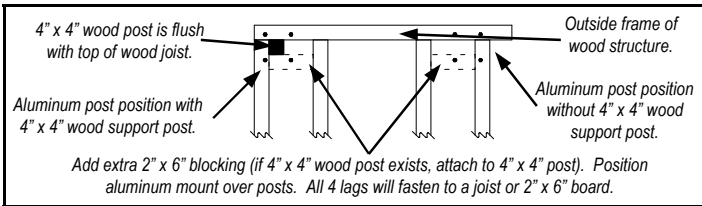

When installing an aluminum post on top of a vinyl decking system, an aluminum adapter kit will be needed. The kit contains (4) 1/4" x 5" stainless steel lags and (4) 1 1/2" aluminum bushings.

3. Use a 1/2" open end wrench to level aluminum post with the leveling bolts on the welded plate.
4. Attach caps. Lightly tap with rubber mallet if needed.

Angle (Swivel) Mount

NOTE: Angle (Swivel) Mounts must be unassembled to be installed properly.

1. Attach to posts by removing the set-screw located on the inside of the angle mount.
2. Unscrew set-screw, remove retaining pin from the base.
3.
 - a. Position bottom mount base so the bottom of the rail has no more than a 2" clearance. NOTE: A 1 3/8" spacer may be placed on the welded 3/8" plate of the post to reach the 2" clearance.
 - b. Measure up 27 1/2" (for 36" tall railing) or 33 1/2" (for 42" tall railing) from top of bottom mount to top of mid rail mount.
 - c. Measure up 5 1/8" from top of mid rail mount to top of top mount.
4. Keeping base of mount centered and pin hole turned down, fasten base to post with self-tapping screws (provided).
5. Re-assemble mount with pin and set-screw.
6. Angle swivel mount after mount is installed on post. Measure from back of cup to back of cup. Cut rails.
7. Assemble sections as specified in Standard (Level) Railing.

Standard (Level) Railing

NOTE: Top rail is 1" longer on each end to accommodate Crossover Railing.

1. Cut the rails to length by holding rails against posts. Position so there will be the same spindle spacing on each end of the rails. Mark rails where they are to be cut. NOTE: Make sure rail is cut a 1/4" shorter on each end to allow for mounts. Cut rails.

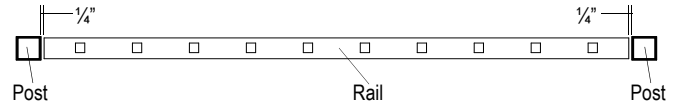

Crossover Railing - Cut bottom and mid rails same as above. For top rail, make end spacing exactly 1" longer on the end connecting to the crossover post.

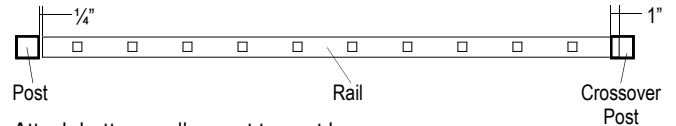

2. Attach bottom wall mount to post by positioning the bottom rail so there is no more than a 2" clearance. Keeping mount centered on post, fasten mount to post with self-tapping screws (provided). NOTE: A 1 3/8" spacer may be placed on the welded 3/8" plate of the post to reach the 2" clearance.

3. Attach mid rail wall mount to post by measuring up 27 1/2" (for 36" tall railing) or 33 1/2" (for 42" tall railing) from top of bottom mount to top of mid rail mount. Keeping mount centered on post, fasten mount to post with self-tapping screws (provided).

4. Attach top wall mount to post by measuring up 5 1/8" from top of mid rail mount to top of top mount. Keeping mount centered on post, fasten mount to post with self-tapping screws (provided).

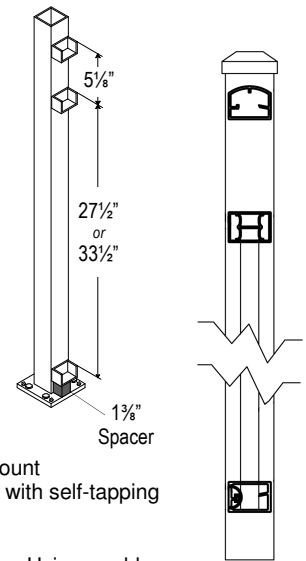

5. Place bottom rail on a clean, flat surface. Using a rubber mallet, tap spindles into routed holes making sure spindles are seated all the way into the rail. Hold mid rail at an angle above the spindles. Starting at one end, feed first spindle into routed hole and tap lightly. Feed remaining spindles into rail, tapping lightly as you move to the other end making sure all spindles are seated against the top rib. Insert assembled section into bottom and mid rail mounts by lightly tapping with a rubber mallet. Secure section with screws through mid rail mounts into mid rail. Snap covers on bottom and mid rail mounts.

6. Using a rubber mallet, tap short spindles/rings into top of mid rail. Insert top rail into top mounts by lightly tapping with a rubber mallet. Secure rail with screws through mounts into top rail. Snap covers on top rail mounts.

7. Attach 2-piece flairs to all posts.

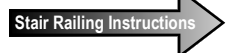

Riviera Series

(Styles C30, C301, C30R, C301R, C31, C311, C32, C321, C33, C331, C34, C341)

Installation Instructions...Continued



Stair Railing

IMPORTANT: Rails have to be positioned in the correct direction prior to cutting. If rails are not in correct position they may be cut incorrectly and spindles will not line up.

1. Identify top, mid, and bottom stair rails. (See Example 1.)
2. Lay bottom rail on steps beside posts. Insert a spindle into the last hole on each end. Place mid rail on these spindles. Insert a spindle into (top side of mid rail) the last hole on each end of the mid rail. Place top rail on these spindles.
3. Position rails against posts and even the end spacing on each end with pickets parallel to the post. (See Example 2.) Mark rails for cutting. Cut rails $\frac{5}{16}$ " shorter than the mark on each end.
4. For Crossover Stairs, angle top crossover unit to match the angle of the stair and cut accordingly.

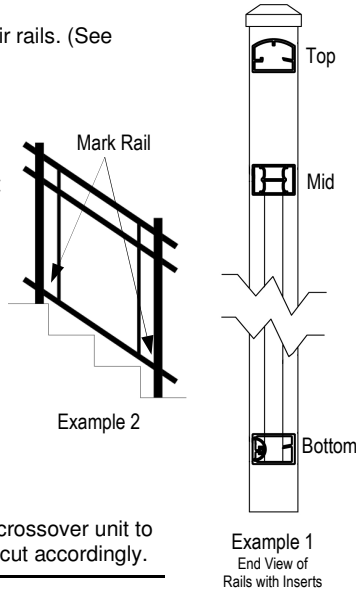

NOTE: Experienced installers can cut the same amount off each rail end and cut the rails on a 90° angle rather than the angle of the stair. Cutting rails on a 90° angle allows the mounts at the top 2 rails of the stairs to be installed while the rail is seated in the mount.

5. Position bottom rail 1" above the nose of the steps (use 1" spacers) and mark where the brackets are to be attached to the posts. (See Example 3.) Attach mounts with flat head self-tapping screws (provided).
6. Insert spindles into bottom rail. Seat completely into bottom rail by tapping with rubber mallet. Insert mid rail onto pickets by starting at the top end and working towards the bottom of the stairs. Remove section from bottom mounts and repeat same steps to attach mid rail to posts with stair mounts. *NOTE: Spindles are cut for a 34° angle. If a different angle is needed, spindles may need to be cut to proper stair angle.*
7. Insert short spindles into top of mid rail. *NOTE: Make sure angle cut on spindles is parallel with the angle of the stairs. (See Example 4.)* Repeat steps for mid rail to attach top rail to posts with mounts.

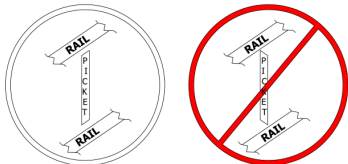

Example 4

8. Attach stair rail to brackets by inserting flat head self-tapping screws (provided) into the side of the brackets. Lightly tap mount covers onto mounts. *NOTE: Use caution when installing mounts by applying pressure directly on top of the mount tab.*
9. Attach flairs to all posts.

Swivel Stair Mount

NOTE: Swivel Stair Mounts must be unassembled to be installed properly.

1. Lay bottom rail (with approximately 1" clearance from the nose of the steps) beside the posts. Determine where the end holes will be on each end and place a spindle in those holes. Place mid rail on these spindles. Holding rails against posts, determine end spacing making sure end spacing is even between post and spindles. Hold swivel stair mounts up against posts and beside the rail to determine where rails are to be cut to fit inside the swivel stair mounts. *NOTE: This will vary depending on angle of stairs.* Cut rails. Cut top rail at same length and angle as bottom and mid rails.

Crossover Railing - Cut bottom and mid rails same as above. For top rail, make sure crossover connector is set at proper angle. Mark rail to cut making sure it fits snug into the crossover connector. *NOTE: Crossover post and connector will need to be installed first to determine what length the rail will be cut.* Cut rail.

2. Attach bottom swivel mounts by removing the set-screw located on the inside of the swivel mount. Unscrew set-screw, remove the retaining pin from the base. Bottom swivel mount base is to be positioned (keeping base of mount centered and pin hole on one side) so the bottom rail has approximately 1" clearance from the nose of the step. *NOTE: A 1" spacer may be placed on the nose of the step to reach the 1" clearance.* Fasten base to post with self-tapping screws (provided). Re-assemble mount with pin and set-screw.
3. Attach mid rail swivel mounts by removing the set-screw located on the inside of the swivel mount. Unscrew set-screw, remove the retaining pin from the base. *NOTE: Keep base of mount centered and pin hole on one side.* Fasten base to post with self-tapping screws (provided). Re-assemble mount with pin and set-screw.
4. Attach top swivel mounts by removing the set-screw located on the inside of the swivel mount. Unscrew set-screw, remove the retaining pin on the base. *NOTE: Keep base of mount centered and pin hole on one side.* Fasten base to post with self-tapping screws (provided). Re-assemble mount with pin and set-screw.
5. Follow steps as specified in Stair Railing instructions.

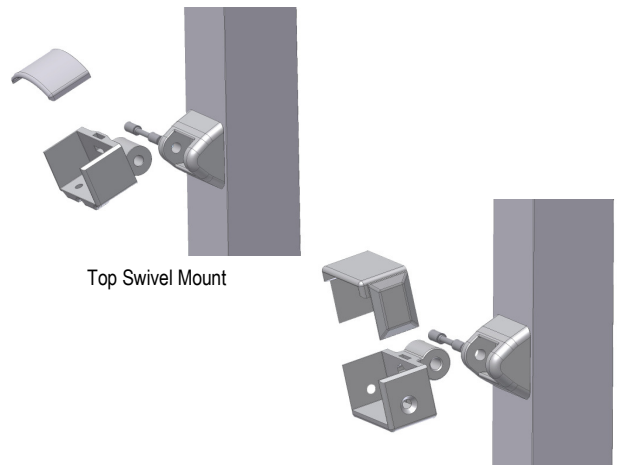

Top Swivel Mount

Bottom and Mid Swivel Mount