

ScreenRail

Installation Instructions



- These instructions must be followed exactly as written and the materials used must be exactly as shown in the instructions. Any deviation from the instructions or variation in the materials used/installed may result in an unsuccessful installation.
- Tools Recommended: Hammer, Tape Measure, Miter Saw (with aluminum cutting blade), Screw Gun (with #2 square drive bit), Drill (with 3/16" bit), Level, Non-scuffing Mallet or Wood Block.

POST AND SCREENRAIL FRAME RAILS

ScreenRail Posts and Frame Rails Consist of: Post, Post Mount with screws, Rail with cover, Rail Mount with cover and screws. (Illustrations P1 and P2.)

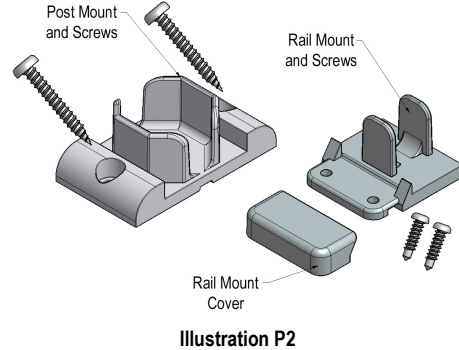
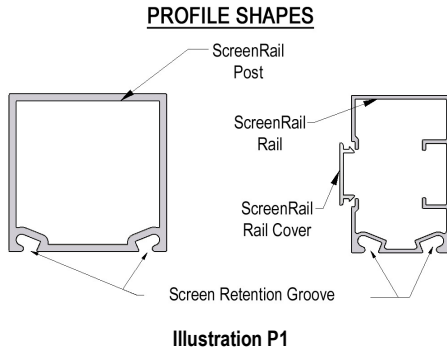

Step 1: Determine spacing of vertical posts to match the widths desired for installing screen you will use. An equal (or near equal) spacing of posts will give your room a more esthetically pleasing appearance. Narrower widths of screen are easier to install and are affected less by wind than wide screen widths. (NOTE: Between post spacing should be 6" less than screen width.)

Step 2: Screen retention grooves (Illustration P1) are needed at all vertical and horizontal perimeters that are to be screened in. Screen retention grooves must always be on the side the screen is to be attached. (NOTE: Install all vertical posts and rails prior to installing horizontal rails.)

Step 3: Measure height for posts. Cut post 1/2" shorter to allow for a post mount at each end.

Step 4: Attach post mounts (Illustration P3) with #14 x 1-3/4" screws (provided) or appropriate fastener for the surface to be attached to. (Concrete anchors, TapCons, etc.) NOTE: Screw hole has to be on side of post with screen retention grooves.

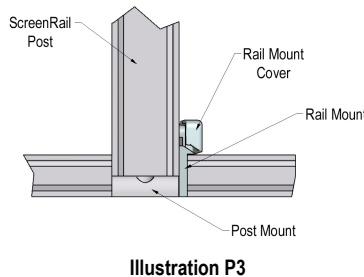

Step 5: Cut rail to desired length. (Illustration P4.) Attach rails with appropriate stainless steel fasteners 16" on center.

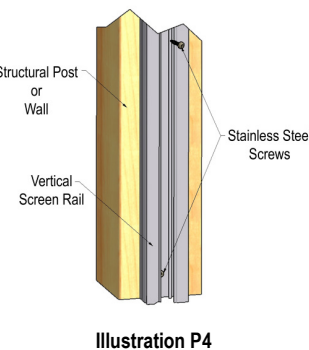

Step 6: Cut rail covers to the same length as the rail. NOTE: A hole is drilled in one end of the covers for the powder coating process. Be sure to cut off the end with the hole. (Hint: Slide one side of the cover into the retaining slot and snap cover on by starting at one end and working toward the other end. Snap cover onto rail.) (Illustration P5.)

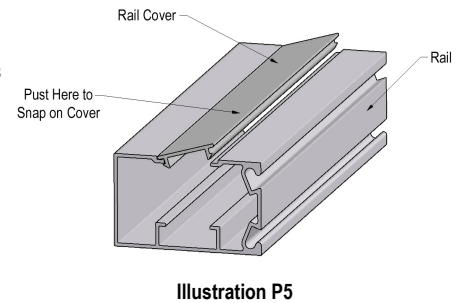

Step 7: Cut horizontal to desired length. (Illustration 6.)

Option A: Surface Mount Rails

Cut the rail to the exact length between vertical rails or posts positioned in previous steps. Attach rails with appropriate stainless steel fasteners 16" on center.

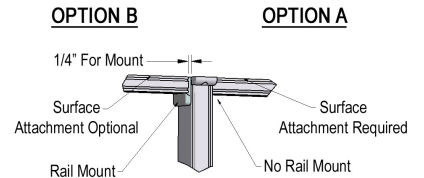

Option B: Rail Mounts

Cut the rail 1/4" shorter per mount (total 1/2" for 2 mounts) than the distance measured between the vertical rails or posts. Attach rails with appropriate stainless steel fasteners 16" on center.

Step 8: Cut screen rail covers to the exact length of the rails and snap them onto the rail. NOTE: A hole is drilled in one end of the covers for the powder coating process. Be sure to cut off the end with the hole. Where mounts are used, cut the cover retainer hooks off. (Illustration P7.)

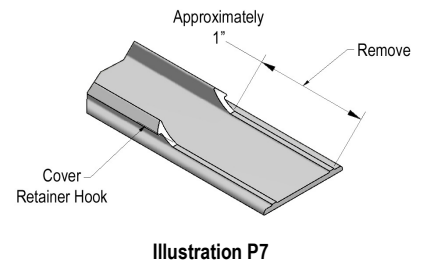

SCREENRAIL RAILING SECTION

ScreenRail Railing Section Includes: (2) Rails with covers and plastic spindle retainers, (4) Wall Mounts with covers and screws, and Spindles (amount depends on section length).

Step 1: Make sure plastic spindle retainers are in the railing. (Illustration R1.)

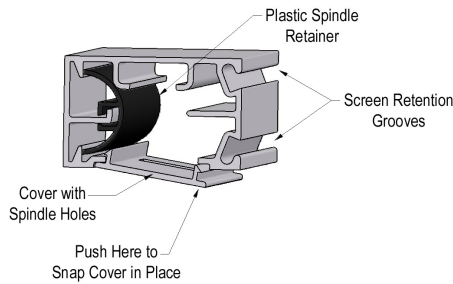

Illustration R1

Step 2: Remove the cover from both rails.

Step 3: Cut the bottom rail to fit tightly in the section area. (Allow 1/4" on each end if using mount to attach rail to posts. Total of 1/2" shorter than opening.) *NOTE: Make sure screen retention grooves are positioned toward the side that the screen is to be installed when performing the next steps.*

Step 4: Secure the bottom rail.

Option A: Surface Mount Bottom Rail

Attach the rail securely to the floor or other mounting surface. Space the rail about 1/16" off of the floor to allow water to drain using flat stainless steel #12 washers or other thin spacers. **Note: Spacers and floor attachment fasteners are not provided.** Drill (2) 1/4" drain holes in the bottom rail.

Option B: Rail Mount Bottom Rail

Note: rail needs to be cut 1/2" shorter for rail mounts. Insert mounts into bottom rail. Attach each mount with (2) #8 x 3/4" stainless steel self-tapping screws (provided).

Step 5: Position a ScreenRail cover beside the bottom rail so there is equal spacing between the end spindle holes and the vertical surfaces at each end of the section. (Illustration R2.) Mark the rail cover and cut it to the exact length between the vertical surfaces or mounts. Snap the cover onto the Rail (Illustration R1.)

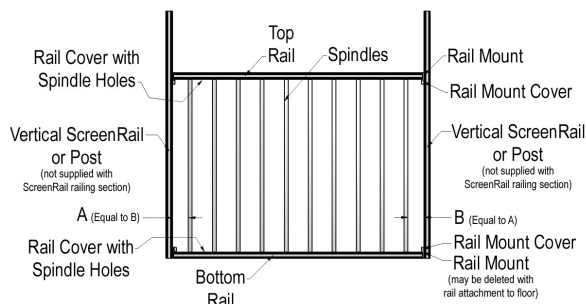

Illustration R2

Step 6: Insert all spindles into bottom rail.

Step 7: Cut the top rail 1/2" short to allow for wall mounts.

Step 8: Lay the top rail cover beside the bottom rail cover and align the holes. Cut cover to the required length. *NOTE: deduct 1/4" from each end of the top cover if mounts were NOT used to install the bottom rail.* (Illustration R3.)

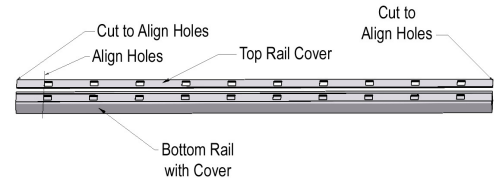

Illustration R3

Step 9: Snap the rail cover onto the rail and slide the plastic spindle retainer into the rail. (Illustration R1.)

Step 10: Put a rail mount on each end of the rail. Turn the holes for the attachment of the mount **down**. (Illustration R2.)

Step 11: Place top rail on spindles. **Be sure the screen retention grooves are toward the side you want the screen to be attached to.** Start at one end and guide each spindle into the hole in the cover. (Illustration R4.) When all spindles have been started, gently push down on the top rail to seat all the spindles completely.

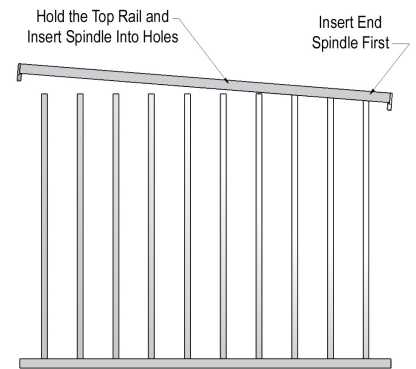

Illustration R4

Step 12: Attach top rail with #8 x 3/4" stainless steel self-tapping screws (provided) through the rail mounts.

Step 13: Install the mount covers over the screws. (*Hint: Place one side of the cover so the retaining notch is in the lock position. Place a block of wood against the side of the cover that is not locked. Tap gently to snap the cover in place. Note: Instead of a wood block, a rubber or other non-scuffing mallet may be used.*) (Illustration R5.)

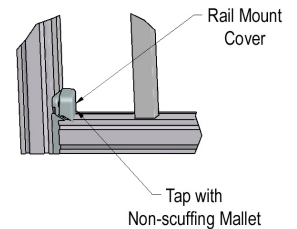
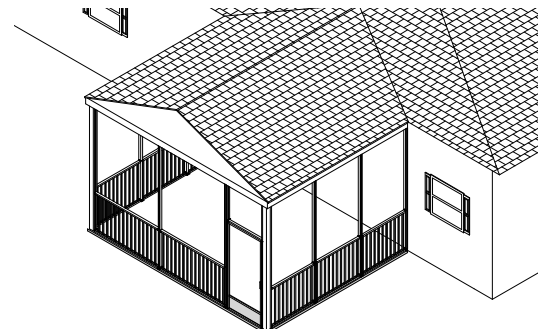

Illustration R5



Example shown with ScreenRail Railing Sections

SCREENRAIL KICK PANEL SECTION

ScreenRail Kick Panel Includes: (2) Rails with covers, (2) Vertical Rails 11-1/4" with 13" covers, (1) 2-pack Wall Mounts with covers and screws.

Step 1: Cut the longest rail to desired length. Install by attaching it to the floor or other mounting surface with appropriate stainless steel fasteners 16" on center. Space rails about 1/16" off of the floor to allow for water drainage. Support rail with flat stainless steel #12 washers or other thin spacers. **Note: Spacers and floor attachment fasteners are not provided. (Do NOT use kick panel rail mounts on the bottom rail.)** Drill (2) 1/4" drain holes in the bottom rail. **Be sure the rail is aligned with the screen retention grooves on the existing ScreenRail components and is turned toward the side the screen will be installed.**

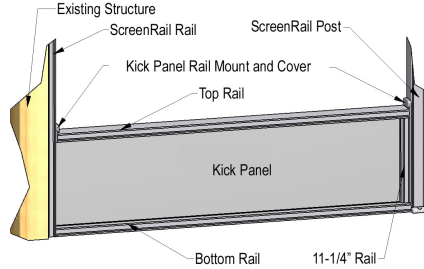

Illustration K1

Step 2: Cut a Kick Panel rail cover to the same length as the screen rail. **Note: A hole is drilled in one end of the cover for the powder coating process. Be sure to cut off the end with the hole. (Hint: Slide one side of the cover into the retaining slot and snap cover on by starting at one end and working toward the other end.)** (Illustration K2.)

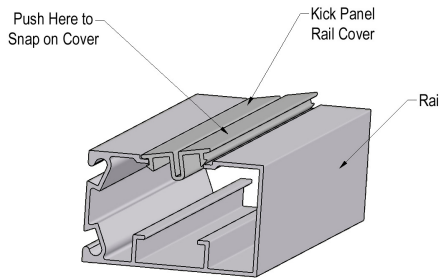

Illustration K2

Step 3: Kick Panel Section Against a ScreenRail Post:

Attach (1) 11-1/4" rail against the post. (Illustration K1.) Attach the rail with #8 x 3/4" screws (provided). Keep sides of the rail even with the sides of the post (Illustrations K1 and K3.) Cut (1) 13" Kick Panel rail cover to 11-1/4" and snap it onto the 11-1/4" rail. (Illustration K2.)

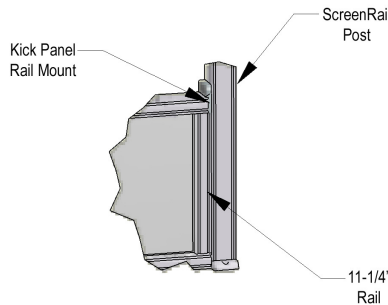

Illustration K3

Kick Panel Section Attached to a Vertical ScreenRail: Cut 13" from the standard cover and replace with the 13" Kick Panel cover (provided). (Illustration K4.)

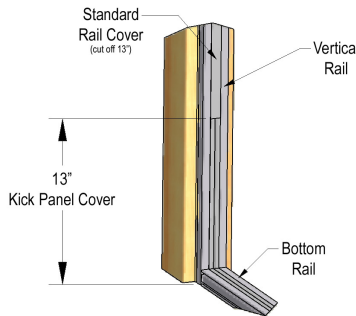

Illustration K4

Step 4: Cut aluminum panel 1/2" longer than the in-between measurement. Install the Kick Panel.

Step 5: Cut top rail and cover 1/2" shorter than the opening to allow for mounts.

Step 6: Snap the cover onto the rail.

Step 7: Place rail assembly with mounts over the top edge of the Kick Panel. (Illustration K5.)

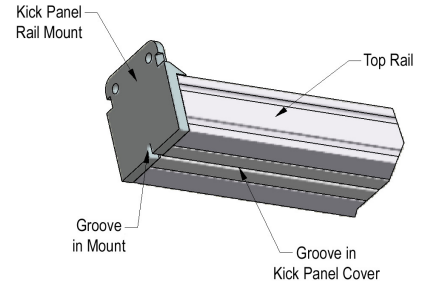

Illustration K5

Step 8: Attach the mounts to the vertical post or rail with (2) #8 x 3/4" screws (provided).

Step 9: Install the mount covers over the screws. (Hint: Place one side of the cover so the retaining notch is in the lock position. Place a block of wood against the side of the cover that is not locked and tap gently to snap the cover in place. Instead of a wood block, a rubber or other non-scuffing mallet may be used.) (Illustration K6.)

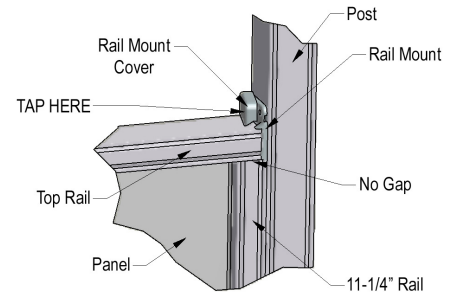
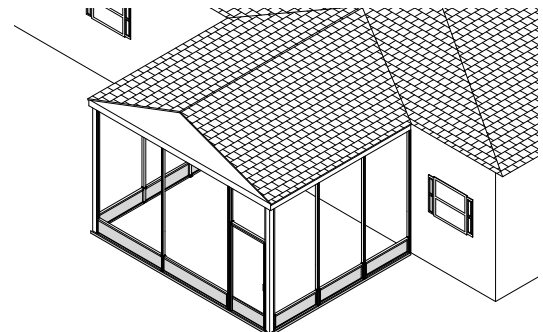

Illustration K6



Example shown with ScreenRail Kick Panel Sections

SCREENRAIL DOOR

ScreenRail Door Includes: Screen Door Frame, (2) Hinges, (1) Latch, (1) Closer Set, Header Jamb, Hinge Jamb, and Latch Jamb.

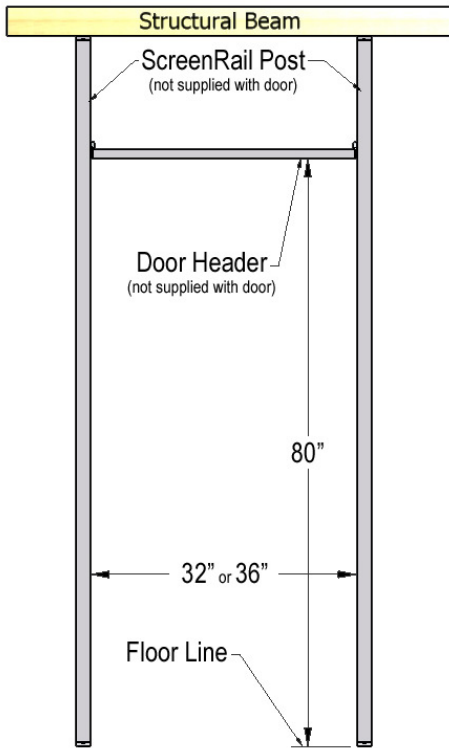

Illustration D1

Step 1: Posts on either side of the door should extend from the floor to a solid (structural) horizontal member above the door. Posts must be spaced apart the width of the door call size (32" or 36"). A post must be used on the hinge side of the door. A vertically installed rail that is tight against a post is acceptable for the latch side of the door. Use a level or square to be sure the opening is square.

Step 2: Install a horizontal rail (Door Header) 80" from the floor in the door opening to be the top piece for the rough opening of the door. *NOTE: This is not supplied with the door but is a separate item that may be purchased from the door supplier. Do not allow anything to protrude into the door rough opening area.* (Illustration D1.)

Step 3: Attach top jamb to header with appropriate stainless steel screws (provided). Keep the jamb tight against the header.

Step 4: Attach hinge side jamb (the jamb with hinge holes) to post with appropriate screws (provided). (Illustration D2.) **Do not attach the jamb with screws through the hinge holes at this time.**

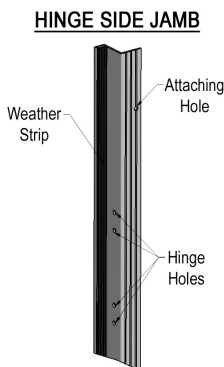

Illustration D2

Step 5: Attach hinge to door. Door can be installed with screen retention grooves toward the inside or outside and may be either left or right hand hinged. Use only the center portion of the hinge to attach hinge to door. *(NOTE: This portion of the hinge has a contour that will fit into the outer edge of the door frame.)* There are small center marks on the door to designate the center hinge screw location. These are 9-1/16" from the top of the door. Install (3) screws per hinge. **Do NOT over tighten screws.** (Illustration D3.)

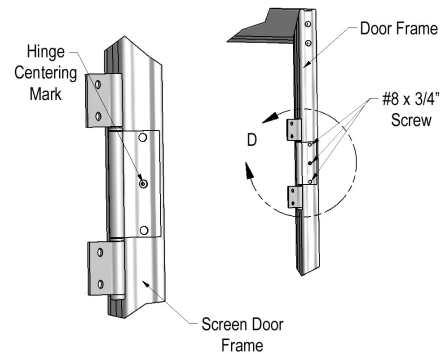

Illustration D3

Step 6: Attach door to the ScreenRail post through the jamb with appropriate stainless steel screws (provided) in each hole. The jamb has been pre-drilled to assist in positioning the door to the jamb and post. (Illustration 4.)

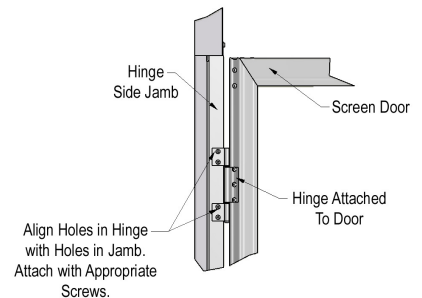

Illustration D4

Step 7: Attach latch side jamb by placing it in position and closing the door. Check to see that the jamb is positioned properly and attach it with appropriate screws (provided).

Step 8: Install latch and other hardware to complete installation. Follow the instructions included with the latch and closer mechanism.